

J.ADAMS&Co

ARAGON PENDANT (US WIRED)



LIGHT SOURCE:

GU10 LAMP BASE
(4W MAX LED ONLY)

LAMP SUPPLIED:

1 X GU10 LED / 3000K / 4W /
250 LUMENS

DIMMABLE:

PHASE DIMMING (USING SUPPLIED
LAMP)

VOLTAGE:

120V AC

CERTIFICATIONS:

UL (ON REQUEST)

MATERIALS:

BRASS, ALABASTER STONE

WEIGHT:

ARAGON 340: 9 LB (APPROX)
ARAGON 420: 13 LB (APPROX)

FLEX:

8' AS STANDARD

HANGING OPTIONS:

- DROP ROD AT 100MM INCREMENTS
(SPECIFY DROP WHEN ORDERING)

ADDITIONAL INFO:

DESIGNED BY WILL EARL 2020
MADE IN ENGLAND

ARAGON 340:

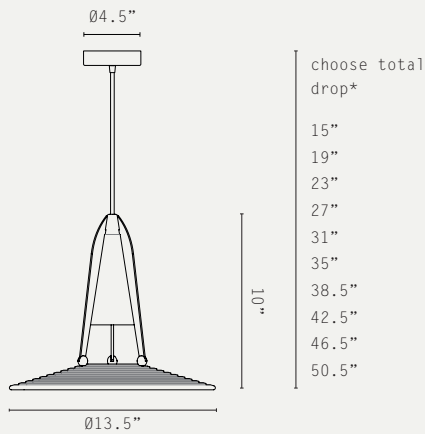

ARAGON 420:

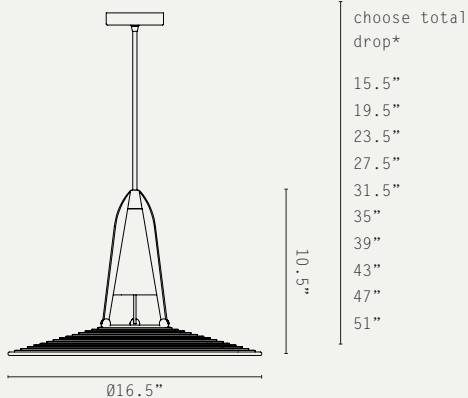

*longer drop available at extra cost

METAL FINISHES:

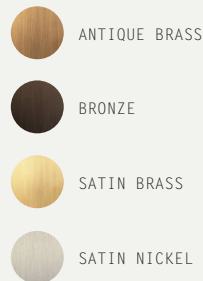

PRODUCT CODES:

ARAGON 340

U.ARA.P34.R.AB.WA - ANTIQUE BRASS / ALABASTER
U.ARA.P34.R.BZ.WA - BRONZE / ALABASTER
U.ARA.P34.R.SB.WA - SATIN BRASS / ALABASTER
U.ARA.P34.R.SN.WA - SATIN NICKEL / ALABASTER

ARAGON 420

U.ARA.P42.R.AB.WA - ANTIQUE BRASS / ALABASTER STONE
U.ARA.P42.R.BZ.WA - BRONZE / ALABASTER STONE
U.ARA.P42.R.SB.WA - SATIN BRASS / ALABASTER STONE
U.ARA.P42.R.SN.WA - SATIN NICKEL / ALABASTER STONE